

# Typ/Type SN 5 FL

## Drehstrom Schneckengetriebe-Motoren Worm gear drives with three-phase motors



RUHRGETRIEBE

IP 54, 230/400 V, 50 Hz

Motor und Getriebe in Kugellagerung, Schnecken gehärtet und geschliffen, Schneckenräder aus Sonderbronze.  
Ball bearings for motor and gear; worms hardened and ground; wormwheel made of special bronze alloy.

Auch möglich:  
Also possible:

∅d <sub>1</sub>	∅d <sub>2</sub>	∅d <sub>3</sub>	∅s <sub>1</sub>	q <sub>1</sub>	q <sub>2</sub>
90	75	60	M5	24	105
110	80	60	M6	24	105

Belastbarkeit der Abtriebswelle Loading capacity of the output shaft	
radial/radially	120 N
axial/axially	80 N

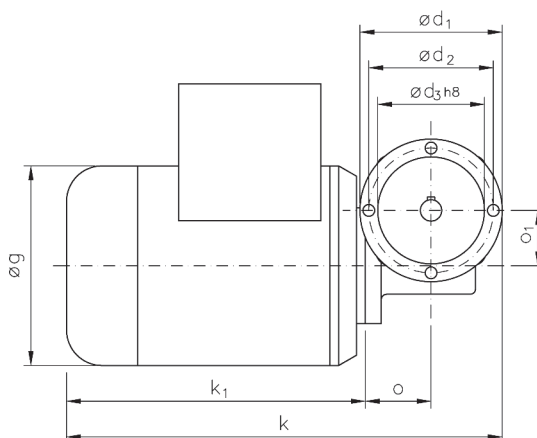
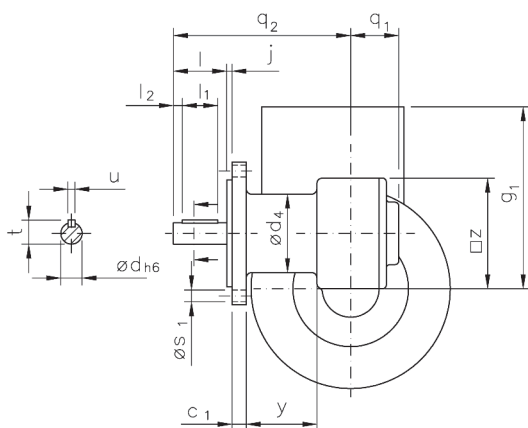

Andere Wellenmaße auf Anfrage!  
Other shaft dimensions on request!

Maße ohne Toleranzangabe sind unverbindlich!  
Dimensions without tolerances are not binding!

Watt (U/min)	Befestigungsmaße/Mounting dimensions							Raummaße/Outline dimensions										Wellenmaße/Shaft dimensions					
	c <sub>1</sub>	∅d <sub>1</sub>	∅d <sub>2</sub>	∅d <sub>3</sub>	∅d <sub>4</sub>	j	∅s <sub>1</sub>	∅g	g <sub>1</sub>	k	k <sub>1</sub>	o	o <sub>1</sub>	q <sub>1</sub>	q <sub>2</sub>	y	z	∅d	l	l <sub>1</sub>	l <sub>2</sub>	t	u
32-1400	9	80	70	60	44	3	6,5	88	81	215	138	37	31	27	100	38,5	62	12	30	20	5	13,5	4
90-2800	9	80	70	60	44	3	6,5	107	87	199	122	37	31	27	100	38,5	62	12	30	20	5	13,5	4
45-1400	9	80	70	60	44	3	6,5	112	102	245	168	37	31	27	100	38,5	62	12	30	20	5	13,5	4
90-1400	9	80	70	60	44	3	6,5	112	102	245	168	37	31	27	100	38,5	62	12	30	20	5	13,5	4

## Getriebedaten / Technical data of the gear

Übersetzung i / Gear ratio i	167	100	75	55	50	38	30	24	20	18	15	12	10	8	7	5	4	2,5
max. zul. Drehmoment / max. permissible torque (Nm)	7,0	8,9	8,8	13	11	14	12	11	12	12	13	15	11	12	12	11	11	5,3

Motordaten / Technical data of the motor	<b>32 Watt, 1400 Upm/rpm</b> Gew. ca. 3,5 kg, ca. 0,25 A bei 400 V/weight approx. 3,5 kg; approx. 0,25 A at 400 V																	
Getriebedrehzahl / Gear rotation speed (1/min)	8,4	14	19	25	28	37	47	58	70	78	93	117	140	168	200	280	327	560
eff. Drehmoment / Eff. torque (Nm)	7,2	6,5	4,6	5,2	4,0	4,0	3,2	2,6	2,7	2,4	2,2	1,8	1,5	1,4	1,2	0,9	0,7	0,5

Motordaten / Technical data of the motor	<b>45 Watt unbelüftet / unventilated, 1400 Upm/rpm</b> Gew. ca. 4,6 kg, ca. 0,4 A bei 400 V/weight approx. 4,6 kg; approx. 0,4 A at 400 V																	
Getriebedrehzahl / Gear rotation speed (1/min)	8,4	14	19	25	28	37	47	58	70	78	93	117	140	168	200	280	327	560
eff. Drehmoment / Eff. torque (Nm)	10	9,2	6,4	7,3	5,7	5,6	4,5	3,6	3,7	3,4	3,0	2,6	2,1	1,9	1,2	1,2	1,1	0,6

Motordaten / Technical data of the motor	<b>90 Watt, 1400 Upm/rpm</b> Gew. ca. 4,7 kg, ca. 0,45 A bei 400 V/weight approx. 4,7 kg; approx. 0,45 A at 400 V																	
Getriebedrehzahl / Gear rotation speed (1/min)	8,4	14	19	25	28	37	47	58	70	78	93	117	140	168	200	280	327	560
eff. Drehmoment / Eff. torque (Nm)	20	18	13	15	11	11	9,0	7,2	7,5	6,7	6,1	5,2	4,3	3,9	3,3	2,4	2,1	1,3

Motordaten / Technical data of the motor	<b>90 Watt, 2800 Upm/rpm</b> Gew. ca. 3,5 kg, ca. 0,4 A bei 400 V/weight approx. 3,5 kg; approx. 0,4 A at 400 V																	
Getriebedrehzahl / Gear rotation speed (1/min)	17	28	37	51	56	74	93	117	140	156	187	233	280	336	400	560	654	1120
eff. Drehmoment / Eff. torque (Nm)	10	10	7,1	7,8	6,1	6,1	4,9	4,0	3,9	3,6	3,2	1,8	2,2	2,0	1,7	1,3	1,1	0,7

Motordaten / Technical data of the motor	<b>120 Watt, 2800 Upm/rpm</b> Gew. ca. 4,6 kg, ca. 0,5 A bei 400 V/weight approx. 4,3 kg; approx. 0,5 A at 400 V																	
Getriebedrehzahl / Gear rotation speed (1/min)	17	28	37	51	56	74	93	117	140	156	187	233	280	336	400	560	654	1120
eff. Drehmoment / Eff. torque (Nm)	14	14	9,5	10	8,2	8,1	6,5	5,3	5,2	4,8	4,2	3,6	3,0	2,7	2,3	1,7	1,4	0,9

Nicht über max. zul. Drehmoment belasten! / Do not load above the max. permissible torque!

**Bitte machen Sie bei Ihrer Bestellung folgende Angaben:  
Please include the following specifications with your order:**

Klemmkastenstellung  
Terminal box position

**A                    B                    C                    D**

**Kontakt:**

**RUHRGETRIEBE KG**

H. Pferdenges

Am Förderturm 29

D - 45472 Mülheim an der Ruhr  
Germany

Tel: +49 (0)2 08 – 78 06 80

Fax: +49 (0)2 08 – 49 80 00 oder 49 84 59

[info@ruhrgetriebe.de](mailto:info@ruhrgetriebe.de)

[www.ruhrgetriebe.de](http://www.ruhrgetriebe.de)



**Übersicht und technische Angaben weiterer RGM Getriebe  
Overview and technical specifications of further RGM geared motors**