

RPL050 Planetary Gear

Dimensions with gear stages	a	Weight
1-stage	48 mm	0,6 kg
2-stage	64 mm	0,8 kg

RPL050 Performance Data

i tot.	Stages	Nominal drive speed n_1 [rpm]	Max. drive speed n_1 max. [rpm]	Nominal torque T_{2N}^{*1} [Nm]	Max. acceleration torque T_{2B}^{*2} [Nm]	Emergency stop torque T_{2EMG}^{*3} [Nm]	Circumferential backlash jt [arcmin]	Efficiency level η [%]	Torsional stiffness c_t [Nm/arcmin]	Mass moment of inertia J_1^{*4} [kg cm ²]
5	1	4000	8000	7	14	21	≤ 10	> 97	0,9	0,06
7	1	4000	8000	7	14	21	≤ 10	> 97	0,9	0,06
10	1	4000	8000	7	14	21	≤ 10	> 97	0,75	0,06
25	2	4000	8000	7	14	21	≤ 14	> 95	0,9	0,052
35	2	4000	8000	7	14	21	≤ 14	> 95	0,9	0,052
50	2	4000	8000	7	14	21	≤ 14	> 95	0,9	0,052
70	2	4000	8000	7	14	21	≤ 14	> 95	0,9	0,052
100	2	4000	8000	7	14	21	≤ 14	> 95	0,75	0,052

*1 Service life 20,000 h, $n_2 = 100$ rpm

*2 (max. 1000 cycles an hour. T2B share <5% of the total running time)

*3 (max. 1000 cycles during the lifetime of the gears)

*4 relative to the drive shaft

Fluid grease lubrication (lifetime-lubricated)

Any installation position

Sound pressure level at a distance of 1 m, measured at a drive speed of 3000 rpm < 68 db(A)

Max. axial force relative to the centre of the output shaft: 700 N, $n_2 = 100$ rpm

Max. radial force relative to the centre of the output shaft: 650 N, $n_2 = 100$ rpm

Temperature range: -25 °C to +90 °C



RUHRGETRIEBE

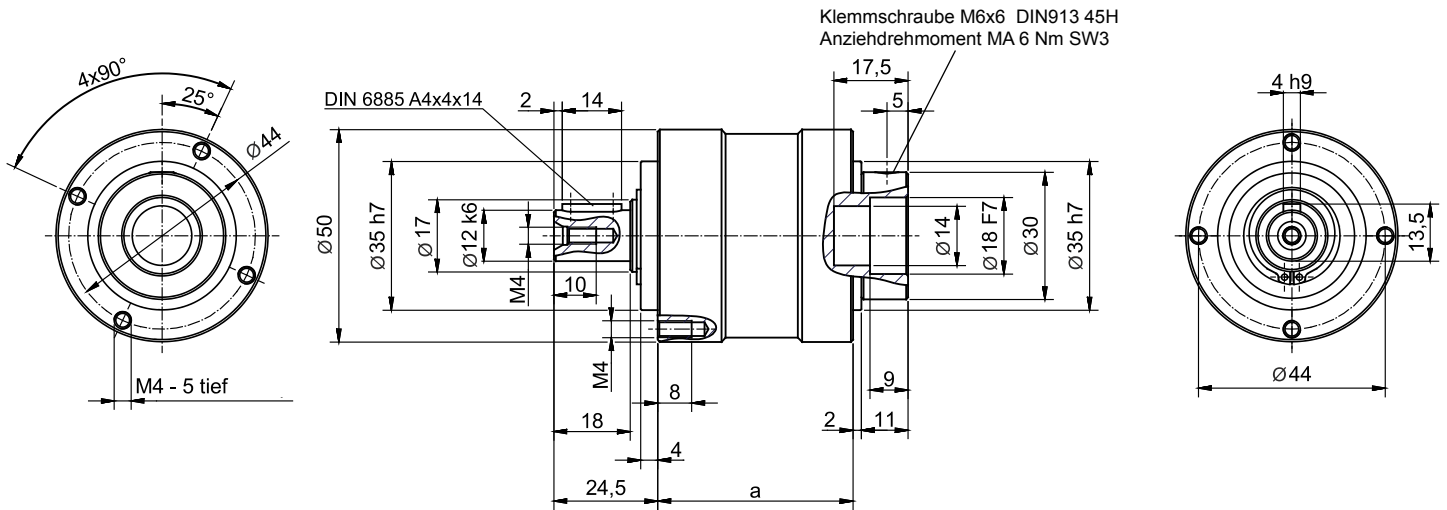

Planetengetriebe RPL050

Maße mit Getriebestufen	a	Gewicht
1-stufig	48 mm	0,6 kg
2-stufig	64 mm	0,8 kg

Leistungsdaten RPL050

i ges.	Stufen	Nenn-Antriebsdrehzahl n_1 [U/min]	Max-Antriebsdrehzahl n_1 max. [U/min]	Nennmoment T_{2N}^{*1} [Nm]	Max. Beschleunigungsmoment T_{2B}^{*2} [Nm]	Not-Aus-Moment T_{2NOT}^{*3} [Nm]	Verdrehspiel jt [arcmin]	Wirkungsgrad η [%]	Verdrehsteifigkeit c_1 [Nm/arcmin]	Massenträgheitsmoment J_1^{*4} [kg cm ²]
5	1	4000	8000	7	14	21	≤ 10	> 97	0,9	0,06
7	1	4000	8000	7	14	21	≤ 10	> 97	0,9	0,06
10	1	4000	8000	7	14	21	≤ 10	> 97	0,75	0,06
25	2	4000	8000	7	14	21	≤ 14	> 95	0,9	0,052
35	2	4000	8000	7	14	21	≤ 14	> 95	0,9	0,052
50	2	4000	8000	7	14	21	≤ 14	> 95	0,9	0,052
70	2	4000	8000	7	14	21	≤ 14	> 95	0,9	0,052
100	2	4000	8000	7	14	21	≤ 14	> 95	0,75	0,052

*1 Lebensdauer 20.000 h, $n_2 = 100 \text{ min}^{-1}$

*2 (max 1000 Zyklen pro Std. T2B-Anteil <5% der Gesamtlaufzeit)

*3 (max 1000 Zyklen während der Getriebelebensdauer)

*4 bezogen auf die Antriebswelle

Schmierung Fließfett (lebensdauer geschmiert)

Einbaulage beliebig

Schalldruckpegel in 1m Abstand, gemessen bei einer Antriebsdrehzahl von 3000 U/min < 68 db(A)

Max. Axialkraft bezogen auf Mitte der Abtriebswelle: 700 N, $n_2 = 100 \text{ min}^{-1}$

Max. Radialkraft bezogen auf Mitte der Abtriebswelle: 650 N, $n_2 = 100 \text{ min}^{-1}$

Temperaturbereich: -25°C bis +90°C



RUHRGETRIEBE